

Performance • Comfort • Style • Innovation • Versatility



LE  PARD ⁴⁴

Introducing



The Leopard 44 represents Robertson and Caine's latest innovative developments with modern features not yet seen on production catamarans, while remaining committed to the tried and tested features that have made the Leopard line one of the most sought after brand of catamarans globally.

In line with Leopard Catamarans reputation of consistently producing award-winning catamarans, the Leopard 44 aims to continue this prestigious track record and sets out to revolutionize the future design of catamarans.



The most significant modification on the Leopard 44 is the addition of the open forward cockpit with direct access from the saloon. Unique to production catamarans this feature offers increased visibility, ventilation, and a significant new approach on adding increased living space in an ergonomic and safe design feature.

True to the Leopard pedigree, the Leopard 44 is a blue water capable yacht that emphasizes functional open spaces and ease of handling while building on design features that have become standard on the modern cruising catamarans.



Leopard 44

Exterior



First introduced on the popular Leopard 46, and continued with each model since, the Leopard 44 features a raised helm station covered by a hardtop bimini. With direct access from the cockpit and weather deck and all lines leading aft, the helm station offers a central and secure location for sail and yacht control.

Both forward and aft cockpits are covered with a continuous hardtop. This creates increased protection from the elements and a stable area for optional solar panels.

Working your way forward, the aft cockpit features an open swim platform, versatile seating with ample storage beneath and a large table. The exterior of the saloon features large acrylic marine windows aesthetically shaped to add to the sleek profile of the yacht while the front vertical windscreens maximize ventilation and visibility forward. The forward cockpit boasts additional seating, storage and a stowable table.



Leopard 44

Interior



Soft overhead LED lighting and a rich cherry wood finish accentuate the spacious interior. Corian surfaces in the galley and micro-fibre fabrics in the saloon add a luxurious feel with proven and durable materials. Interior color options are available.

Large windows provide exceptional panoramic views and allow natural light into the saloon. Door access to the forward and aft cockpits as well as large opening hatches provide plenty of ventilation to this central living space.

The companionway to the owner's suite is to starboard and can be closed off with a sliding cherry finished door for extra privacy (3 cabin layout only).

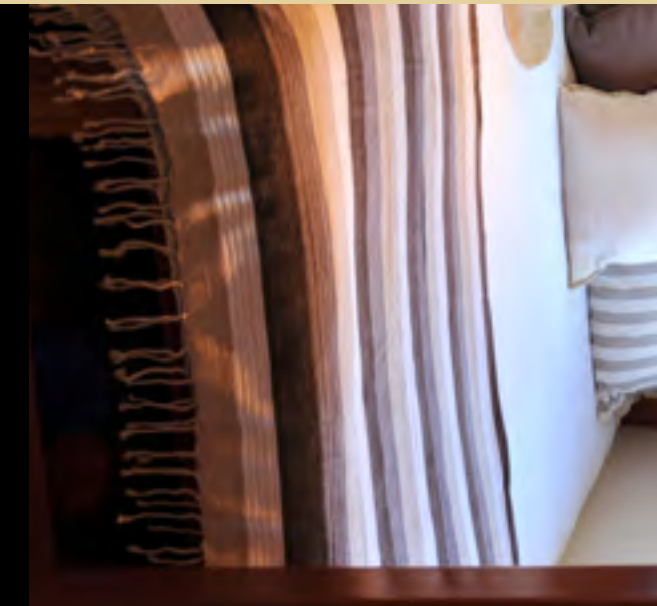

Leopard 44

Saloon and Galley

The Leopard 44 saloon features an L-shaped galley to port with direct serving access to the aft cockpit. The interior settee provides ample seating for up to 8 guests and the dining table can be converted to an optional double berth or coffee table.

Standard appliances include a large stainless steel refrigerator-freezer system to starboard with well-insulated and stylish drawer opening compartments.

The electrical panel, VHF and sound system controls are conveniently located just inside the companionway doors to starboard for ease of access from the saloon, cockpit and helm station.



The ergonomic galley layout features soft curves and heat-resistant Corian counter tops. The galley boasts a standard 3 burner stainless steel stove with oven and broiler, double basin sink with mixer tap, ample counter space and easy access cabinet storage.

The saloon showcases the largest panoramic windows of any Leopard to date with four forward opening hatches and a forward watertight cockpit door providing excellent ventilation and protection.



Accommodations



The Leopard 44 is available in 3 or 4 cabin layouts. The 3 cabin layout features two guest cabins each with en suite head and stall shower in the port hull. The starboard hull is entirely dedicated to the luxurious owner's suite with a spacious master cabin, lounge area with couch, study area, plenty of storage and private head with large stall shower forward.

Well ventilated with opening hatch and ports, there is plenty of storage and excellent lighting in every cabin. Adjustable reading lights, fans, full size hanging lockers, and shelving add to the practicality and comfort of the Leopard 44.



The spacious owner's head and stall shower are located forward in the starboard hull. Amenities include washbasin with mixer tap, shower with adjustable shower head, Corian vanity unit and marine toilet.

Located aft, the master stateroom features a large double berth, book shelf, adjustable reading lights, hanging locker, plentiful shelving for clothing and personal items, as well as additional storage under the bunk. Two opening hatches and two opening ports provide excellent ventilation.

The master suite incorporates a separate study area with dedicated desk, overhead lighting, storage space, and an optional swing seat.

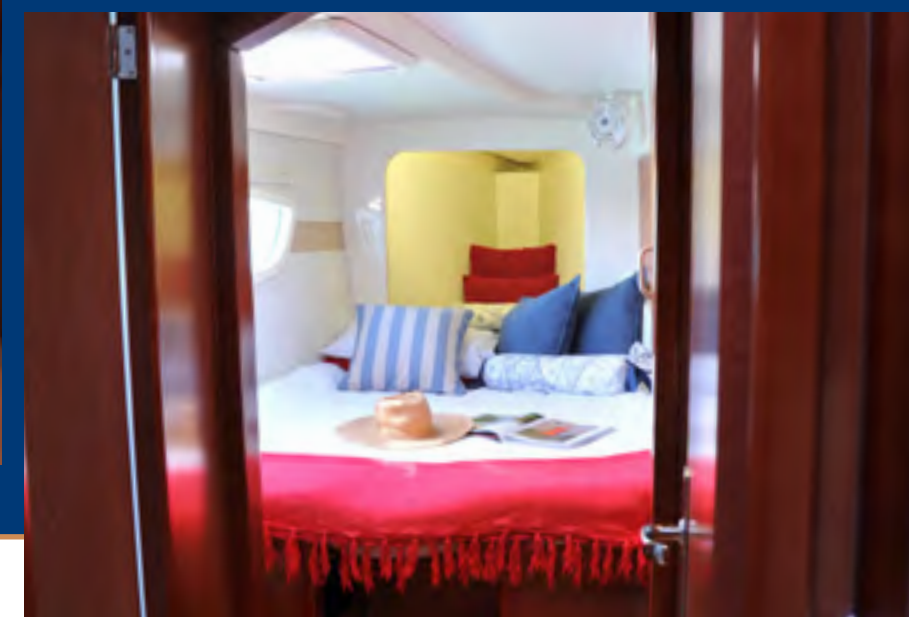

Leopard 44

Unique Features



The Leopard 44's forward cockpit lounging area has direct access from the saloon, as well as a fixed overhead hardtop cover for protection against the elements. The forward door combined with large port lights in the windscreen allow for substantial through ventilation in the saloon, even during inclement weather thanks to the forward hardtop cover.

Allowance has been made for drainage by means of a large sump and underwing scupper, and the forward cockpit door has additional dog clamps to ensure water tightness in heavy sea conditions. In addition, there is provision for installing a splash cover to deflect spray from entering the cockpit.



The raised helm station of the Leopard 44 offers superb visibility and comfortable seating for 2. This unique feature prevents separation of the helmsman from the cockpit which allows for easy interaction with guests and unobstructed views of the transom, for increased safety. All maneuvers can be handled from the helm with sheets and main halyard brought aft to a standard electric primary winch making for easy single-handed sailing.

The Leopard 44 incorporates a built-in internal access stairway to the helm station from the cockpit. This feature offers easier movement from the helm to the cockpit and added safety while offshore. The mainsheet traveler is positioned overhead on the hard-top cover, allowing safe, walk-through access from the cockpit to the aft platform.

The stainless steel davit features an electric winch for ease of storing and deploying of the dinghy, while creating additional space on the transom and saving valuable weight astern.



Leopard 44

Specifications

LEOPARD 44 STANDARD SPECIFICATIONS

Length Overall	42 ft 7 in.	12.98 m
Waterline Length	41 ft 8 in.	12.70 m
Beam	23 ft 9 in.	7.25 m
Draft	4 ft 2 in.	1.27 m
Displacement	27,880 lb	12,615 kg
Mast height	67 ft 10 in.	20.45 m
Water Capacity	206 US gal.	780 l
Fuel Capacity	185 US gal.	700 l
Sail area	1323 sq ft	123 sq m
Engines x 2	29 hp	

The Leopard 44 is equipped using the highest quality materials and top brand fittings. Her unparalleled standards in design and construction for reliability, seaworthiness, and performance, offers excellent value.

The standard equipment can be enhanced by a range of quality optional items including generator, air conditioning, watermaker, solar panels and much more.

Robertson and Caine uses advanced composite GRP sandwich construction. A vacuum bonded E-glass end-grained balsa cored hull ensures a precise resin to glass ratio, and is highly compression and impact resistant. E-glass stitched fabric delivers maximum strength.

Isophthalic gelcoat and resin rich tissue helps prevent osmosis. The hull laminate is light and durable resulting in a dynamic weight carrying capacity and excellent motion reaction of the hull.

Helm Station:

Centralized sail control next to helm position allows for single handed operation, with the genoa and mainsail sheets and the mainsail traveler lines all led aft to the helm.

Huge rope storage compartment keeps deck clear of rope clutter.

Raised helm position allows panoramic view which is enhanced by a fixed port in the hardtop bimini.

Helm station can accommodate up to four.

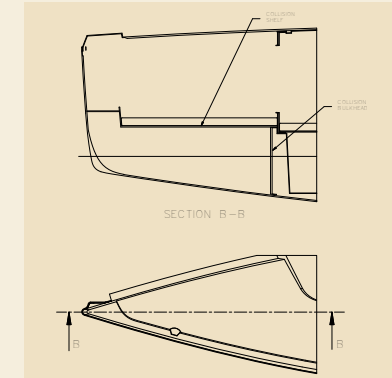
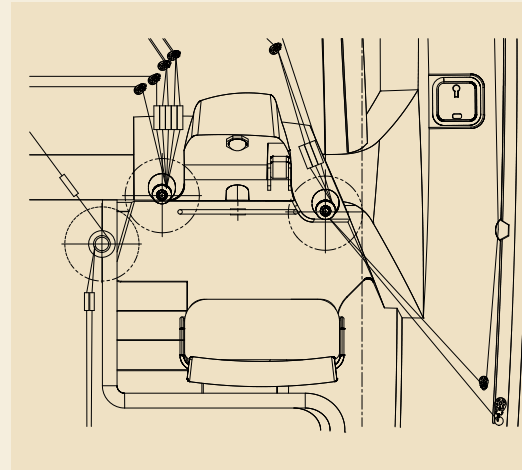

Bulkhead:

The collision bulkheads prevent water intrusion in case of damage to the bows

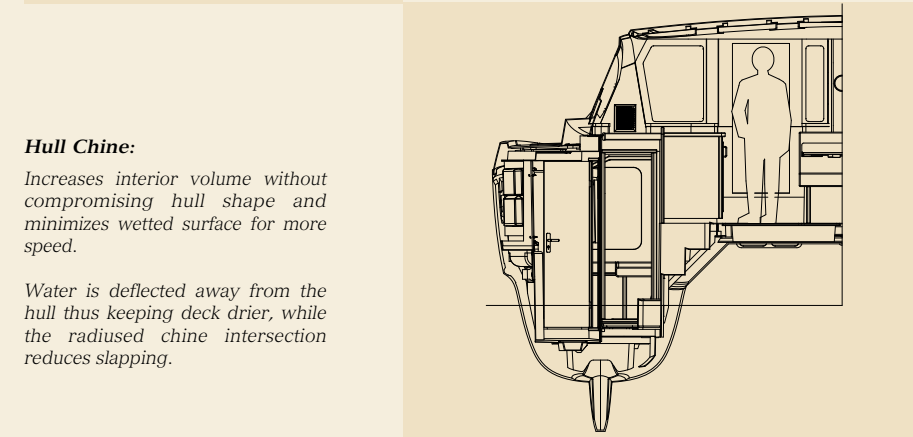

Hull Chine:

Increases interior volume without compromising hull shape and minimizes wetted surface for more speed.

Water is deflected away from the hull thus keeping deck drier, while the radiused chine intersection reduces slapping.

THREE CABIN LAYOUT



FOUR CABIN LAYOUT





LE  PARD
CATAMARANS
www.leopardcatamarans.com